

F115 Ceiling Surface-Mounted Commercial Media Air Cleaner

SPECIFICATION DATA



FEATURES

- Models available with 99.97% HEPA filters or a combination of 95% DOP particulate filters and CPZ sorbent media modules. The filters in both models are more efficient on particles larger and smaller 0.3 micron.
- Single-speed, direct-drive, forward curve blowers/motors deliver up to 600 cfm (1020 cu m/hr).
- Designed to overcome the increase in airflow resistance normally caused by filter loading.
- Light-colored cover complements most ceiling finishes.
- Model available with disposable CPZ™ canister for odor control.

APPLICATION

The F115 Ceiling Surface-Mounted Media Air Cleaner is designed for use in restaurants, conference rooms, lounges and offices where overhead air cleaning is required. The F115 uses direct-drive, forward curve blowers/motors with High Efficiency Particulate Arrestance (HEPA) filters or a combination of 95% DOP (Di-Octyl Phthalate) and CPZ™ (Carbon Potassium Permanganate and Zeolite) sorbent media cartridges for contamination reduction in an enclosed area.

SPECIFICATIONS

Models:

F115A Ceiling Surface-Mounted Media Air Cleaner with 99.97% HEPA filters; without CPZ canisters.

F115C Ceiling Surface-Mounted Media Air Cleaner with 95% DOP filters; with CPZ disposable canisters.

Color:

White plastic cabinet and cover.

Electrical Ratings:

120V, 60 Hz, 1PHS, 7.2A; 220/240V, 50/60 Hz, 1PHS, 3.6A.

Electrical Connections:

J-box hardwired on side and top wired inlet.

Blowers/Motors:

Single-speed, direct-drive blowers/motors.

Air Volume:

600 cfm (1020 cu m/hr).



F115 CEILING SURFACE-MOUNTED COMMERCIAL MEDIA AIR CLEANER

Dimensions:

See Fig. 1.

Weight:

F115A: 65 lb (29.5 kg).
F115C: 64 lb (29 kg).

Controls:

Direct-wired (optional remote mounted On/Off switch).

Sound Level at 3.3 ft (1m):

52 to 56 dBA.

Approvals:

Underwriters Laboratories Inc. Listed.
Canadian Standards Association Certified.

Replacement Parts:

32000206 99.97% High Efficiency Particulate Arrestance (HEPA) Filter (4 required) for F115A1064.
32000217 95% DOP Particle Filter (4 required) for F115C1005.
32000229 Prefilters (Box of 4).
32000229B 10-Pack Prefilter (10 Boxes of 4).
32000232 CPZ Canister (4 Required) for F115C1005.

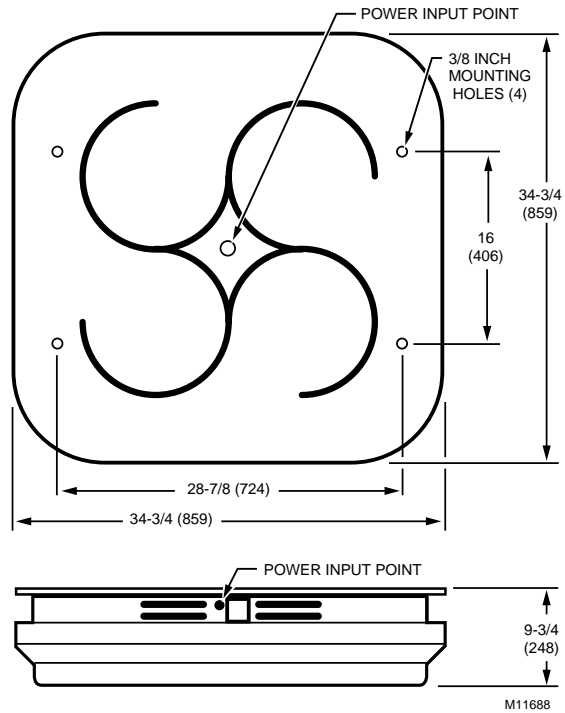

Fig 1. F115 dimensions in in. (mm).

Home and Building Control

Honeywell Inc.
Honeywell Plaza
P.O. Box 524
Minneapolis MN 55408-0524

Honeywell Latin American Region

480 Sawgrass Corporate Parkway
Suite 200
Sunrise FL 33325

Home and Building Control

Honeywell Limited-Honeywell Limitée
155 Gordon Baker Road
North York, Ontario
M2H 3N7

Honeywell Europe S.A.

3 Avenue du Bourget
1140 Brussels
Belgium

Honeywell Asia Pacific Inc.

Room 3213-3225
Sun Hung Kai Centre
No. 30 Harbour Road
Wanchai
Hong Kong

Honeywell

